



# Cambridge International AS & A Level

CANDIDATE  
NAME

|  |
|--|
|  |
|--|

CENTRE  
NUMBER

|  |  |  |  |  |
|--|--|--|--|--|
|  |  |  |  |  |
|--|--|--|--|--|

CANDIDATE  
NUMBER

|  |  |  |  |
|--|--|--|--|
|  |  |  |  |
|--|--|--|--|



**BIOLOGY**

**9700/42**

Paper 4 A Level Structured Questions

**October/November 2022**

**2 hours**

You must answer on the question paper.

No additional materials are needed.

## INSTRUCTIONS

- Answer **all** questions.
- Use a black or dark blue pen. You may use an HB pencil for any diagrams or graphs.
- Write your name, centre number and candidate number in the boxes at the top of the page.
- Write your answer to each question in the space provided.
- Do **not** use an erasable pen or correction fluid.
- Do **not** write on any bar codes.
- You may use a calculator.
- You should show all your working and use appropriate units.

## INFORMATION

- The total mark for this paper is 100.
- The number of marks for each question or part question is shown in brackets [ ].

This document has **28** pages. Any blank pages are indicated.

- 1 The Asiatic lion, *Panthera leo persica*, is found only in the Gir Forest National Park in the Gujarat region of western India.

Fig. 1.1 shows a female Asiatic lion.



Fig. 1.1

- (a) The Asiatic lion is at risk of extinction in the wild and is categorised as endangered by the International Union for Conservation of Nature (IUCN).

Outline the role of the IUCN.

.....  
.....  
.....  
.....  
.....  
.....  
..... [3]

- (b) The Maldhari community is a tribe of herdsmen that lives in the Gir Forest. The Maldhari have co-existed with the Asiatic lions for thousands of years. The Maldhari place old and weak cattle at the edges of their cattle enclosures.

Suggest why the Maldhari place old and weak cattle at the edges of their cattle enclosures.

.....  
.....  
.....  
..... [2]

- (c) Some zoos use assisted reproduction techniques, such as IVF, in their captive breeding programmes for endangered species.

Describe how IVF can be used with an endangered species such as the Asiatic lion.

.....  
.....  
.....  
.....  
.....  
.....  
.....  
.....  
..... [4]

[Total: 9]

2 Yeast cells can respire in anaerobic conditions.

(a) (i) Outline how yeast carries out respiration in anaerobic conditions.

.....  
.....  
.....  
.....  
.....  
.....  
.....  
.....  
..... [4]

(ii) Explain why respiration in anaerobic conditions is an advantage to yeast.

.....  
.....  
.....  
.....  
..... [2]

Bioethanol is a type of biofuel produced from maize starch on an industrial scale. In the high temperature method, heating to 120 °C is used to break apart starch molecules. The enzymes  $\alpha$ -amylase and glucoamylase are added to the resulting starch suspension once it has cooled down. These enzymes hydrolyse the starch to glucose. Yeast cells are then added and maintained in anaerobic conditions to produce ethanol.

The high temperature method is expensive to carry out, so a new method has been developed which heats starch to a lower temperature of 80 °C.

In the lower temperature method, enzymes catalysing the hydrolysis of starch do **not** need to be added to the starch suspension. A genetically modified (GM) strain of the same yeast species is used. The GM strain of yeast has genes that allow the cell to produce  $\alpha$ -amylase and glucoamylase and to attach these enzymes to the external surface of the cell surface membrane. The GM yeast cells are added to the starch that was heated to 80 °C and are maintained in anaerobic conditions to produce ethanol.

(b) An investigation was carried out to compare the GM strain of yeast with the yeast that had **not** been genetically modified (non-GM strain).  
In this investigation, the starch suspension produced after heating to 80 °C was allowed to cool to 30 °C before adding yeast cells.

The results are shown in Fig. 2.1.

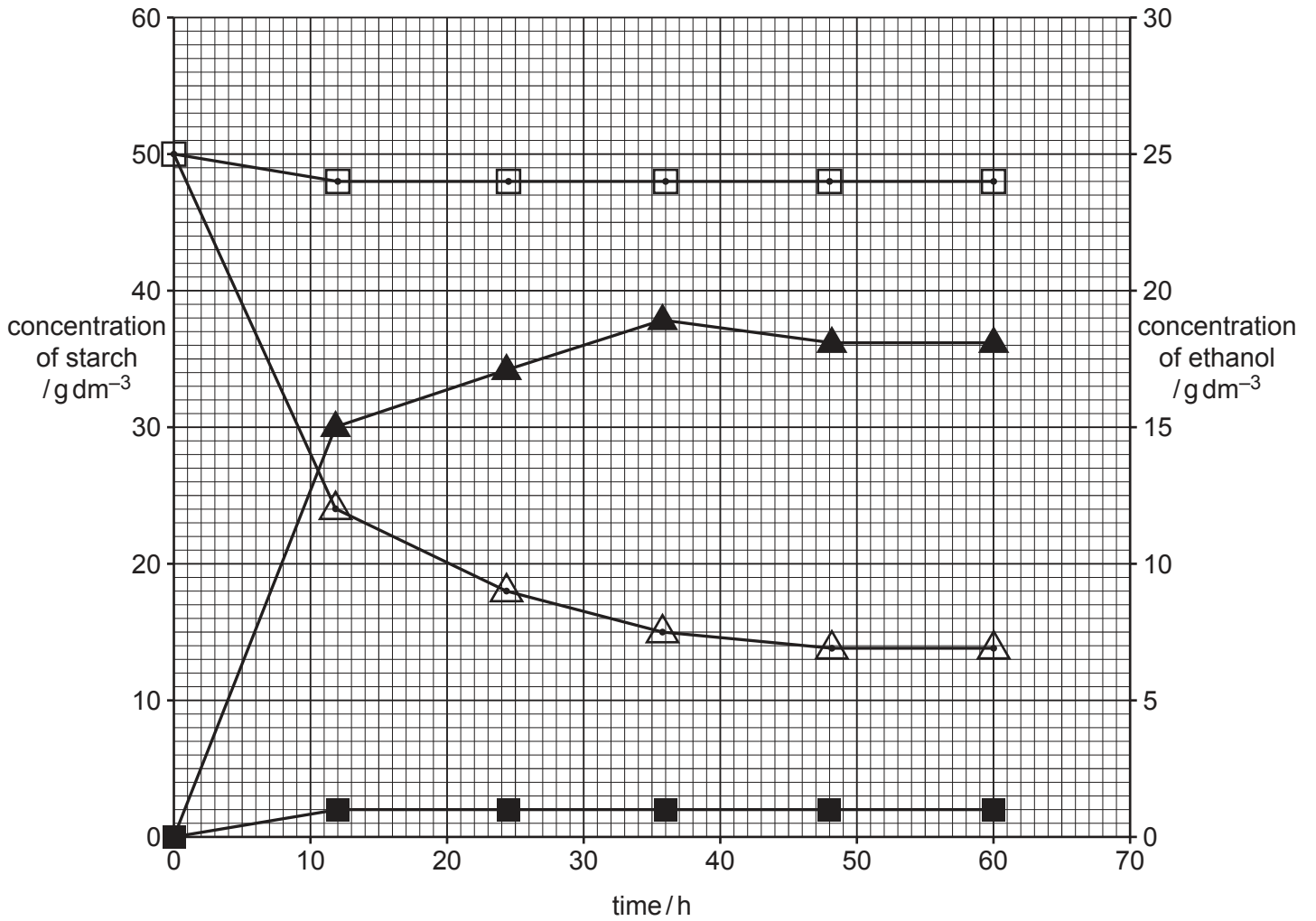

**Key**  
 ■ ethanol concentration using non-GM strain  
 □ starch concentration using non-GM strain  
 ▲ ethanol concentration using GM strain  
 △ starch concentration using GM strain

**Fig. 2.1**

With reference to Fig. 2.1, describe the trends in the data for **ethanol** production by the GM strain compared to the non-GM strain.

.....

.....

.....

.....

.....

.....

..... [2]

- (c) The rate of ethanol production is similar for the lower temperature method and the higher temperature method.

Suggest why using the lower temperature method has a similar rate of production of ethanol to the higher temperature method.

.....  
.....  
.....  
.....  
..... [2]

- (d) Suggest **one** reason why the high temperature method is expensive to carry out.

.....  
..... [1]

[Total: 11]

3 (a) Photosynthesis is an energy transfer process that takes place in chloroplasts of plant cells.

(i) Fig. 3.1 shows a diagram of a chloroplast.

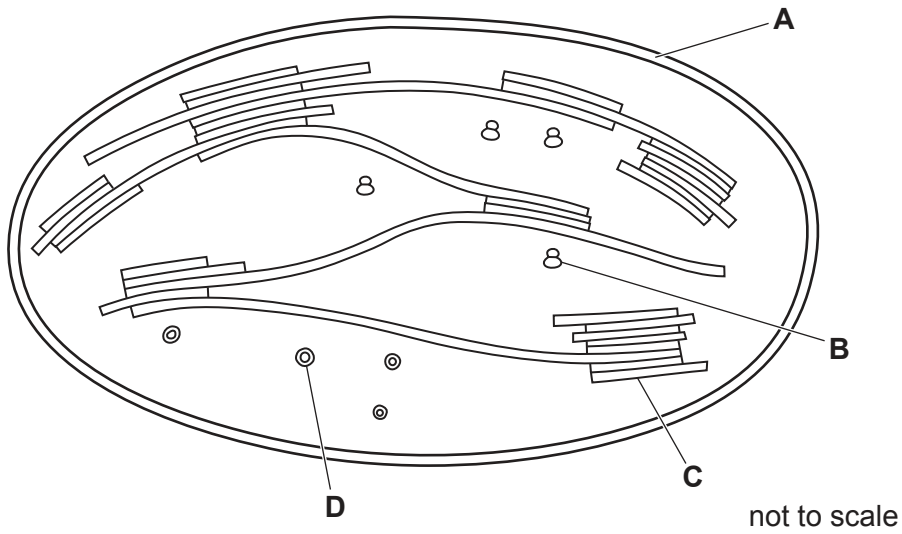

Fig. 3.1

Using the letters **A**, **B**, **C** or **D**, identify the structure that:

- contains genes that code for some of the enzymes used in photosynthesis

.....

- is the site of synthesis of some of the enzymes used in photosynthesis.

.....

[2]

(ii) Explain how grana are adapted for their specific role in photosynthesis.

.....  
.....  
.....  
.....  
.....  
.....  
.....  
.....  
.....  
.....  
..... [4]

(b) An experiment was carried out to investigate the effect of changing light conditions on the pH of the chloroplast stroma. Scientists followed pH changes in chloroplast stroma using fluorescent chemicals that can be used as pH indicators.

- Chloroplasts were isolated from cells.
- A suspension of chloroplasts was prepared and kept in the dark for 180 seconds.
- The chloroplasts were exposed to a period of light of fixed intensity for 240 seconds, then returned to dark conditions.
- The pH of chloroplast stroma was continuously measured and recorded.

Fig. 3.2 shows the results of this experiment.

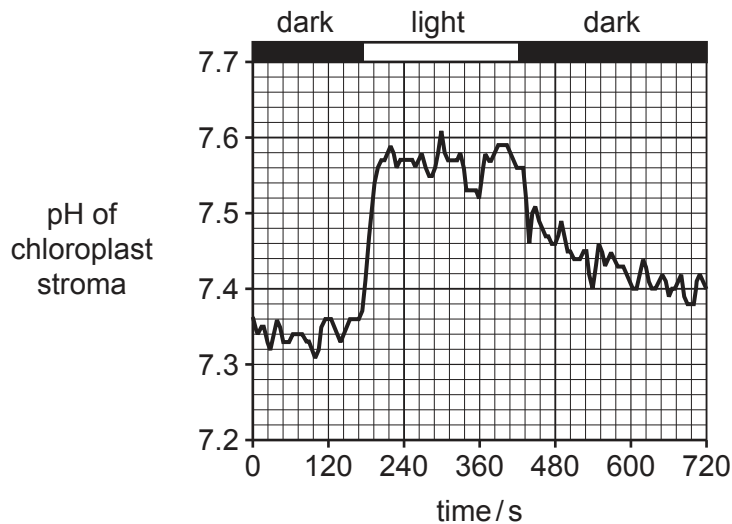

**Fig. 3.2**

(i) Describe the results shown in Fig. 3.2.

.....

.....

.....

.....

.....

.....

.....

.....

..... [3]



(ii) Discuss how the results in Fig. 3.2 support that chemiosmosis occurs during photophosphorylation.

.....

.....

.....

.....

.....

.....

.....

.....

.....

..... [3]

[Total: 12]



(b) Scientists are working towards a goal of treating haemophilia by gene therapy. They plan to use a common, harmless virus to introduce the functional gene. The virus has a genome that is 4.7 kilobase pairs long.

- (i) With reference to Table 4.1 and the introduction to (a), assess:
- which form of haemophilia, A or B, scientists should try to treat first
  - whether they should attempt to treat haemophilia with gene therapy at all.

Explain your reasoning.

.....

.....

.....

.....

.....

.....

.....

.....

.....

..... [3]

- (ii) In gene therapy trials to treat haemophilia, the gene coding for the clotting factor needs to be introduced together with a promoter.

Explain why a promoter has to be introduced as well as the desired gene.

.....

.....

.....

.....

.....

..... [2]

- (iii) Some individuals taking part in gene therapy trials have been naturally exposed to the virus carrying the functional gene, so that their blood already contains antibodies to the virus.

Predict how this will affect the success of the gene therapy treatment.

.....

.....

.....

.....

..... [2]

- (c) Gene editing is a newer technique for modifying DNA. Some scientists are researching the use of gene editing, instead of introducing a functional gene, to treat haemophilia.

State **two** possible advantages of using gene editing as a method of treating haemophilia.

.....

.....

.....

.....

.....

.....

..... [2]

[Total: 13]

5 *Myosotis* is a genus of small flowering plants. Many different *Myosotis* species grow on the islands of New Zealand, which are an important site of *Myosotis* evolution. Lowland *Myosotis* species grow at low altitude while alpine *Myosotis* species grow at high altitude at the tops of mountains.

(a) Scientists wanted to obtain molecular data to determine the evolutionary relationships of New Zealand's *Myosotis* species. They extracted DNA from individuals of *Myosotis* species collected from three different islands in New Zealand.

To carry out a polymerase chain reaction before DNA sequencing, the DNA samples were mixed with primers, deoxynucleotides and *Taq* polymerase and put through 35 cycles of treatment. Each treatment cycle involved one minute at 95°C, followed by one minute at 50°C and then four minutes at 72°C.

Describe what happened to the DNA at each temperature.

.....

.....

.....

.....

.....

.....

..... [3]

(b) Fig. 5.1 shows the three largest New Zealand islands.

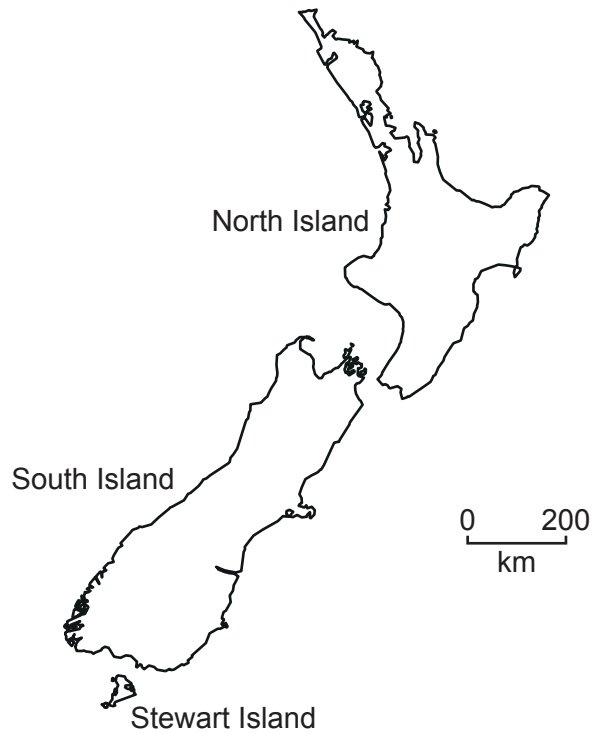

**Fig. 5.1**

North Island has mostly lowland habitat. South Island and Stewart Island have mountains with alpine habitats that are above the tree line.

DNA sequence data for three *Myosotis* species were compared. The results are described in the bullet points.

- In the alpine species *M. pygmaea*, individuals on South Island showed genetic differences from individuals of *M. pygmaea* on Stewart Island.
- In the alpine species *M. pulvinaris*, individuals from different mountains on South Island showed genetic differences.
- In the lowland species *M. pottsiana*, individuals from different areas of North Island showed overall genetic similarity.







(ii) Suggest why structural genes in operons are transcribed together.

.....  
..... [1]

(iii) *trpA* is an example of a structural gene and *trpR* is an example of a regulatory gene.  
Describe the differences between the functions of structural genes and regulatory genes.

.....  
.....  
.....  
.....  
..... [2]

(iv) *trpA* codes for the enzyme tryptophan synthase.  
Tryptophan synthase catalyses the formation of the amino acid tryptophan.  
Explain why tryptophan synthase is an example of a repressible enzyme.

.....  
.....  
.....  
.....  
..... [2]



**Turn over for Question 7.**

- 7 The determination of sex in domestic turkeys is different from that in humans. The sex chromosomes in turkeys are named **Z** and **W**. Male turkeys are **ZZ** and female turkeys are **ZW**.

The gene for feather colour is located only on the **Z** chromosome.

- The dominant allele codes for bronze feathers.
- The recessive allele codes for brown feathers.

(a) Define the terms dominant and recessive.

dominant .....

.....

recessive .....

.....

[2]

(b) Using suitable symbols, construct a genetic diagram to show the results of a cross between a heterozygous bronze male turkey and a brown female turkey.

symbols

parent phenotypes

bronze male

brown female

parent genotypes

gametes

offspring genotypes

offspring phenotypes

[5]

(c) Explain how you would carry out a test cross to determine the genotype of a bronze male turkey.

.....

.....

.....

.....

.....

.....

.....

.....

..... [3]

[Total: 10]



(c) The plasma, the glomerular filtrate and urine are composed of various substances.

Table 8.1 shows the percentage composition of plasma, the glomerular filtrate and urine.

**Table 8.1**

| substance        | percentage composition |                     |       |
|------------------|------------------------|---------------------|-------|
|                  | plasma                 | glomerular filtrate | urine |
| water            | 90.00                  | 90.00               | 94.00 |
| glucose          | 0.10                   | 0.10                | 0.00  |
| amino acids      | 0.05                   | 0.05                | 0.00  |
| plasma proteins  | 8.00                   | 0.00                | 0.00  |
| urea             | 0.03                   | 0.03                | 2.00  |
| other substances | 1.82                   | 9.82                | 4.00  |

As a result of the action of the cells of the proximal convoluted tubule, glucose and amino acids have been reabsorbed by the blood, whereas only some of the urea has been reabsorbed.

Calculate how many times the percentage composition of urea has increased in the urine compared with the glomerular filtrate.

Show your working and give your answer to the nearest whole number.

answer ..... [2]

[Total: 9]

9 (a) Voltage-gated channels are involved in the generation of an action potential.

Fig. 9.1 is a diagram of the voltage-gated channels of sodium ions and potassium ions in the membrane of an axon. The channels are shown in three different states, 1, 2 and 3.

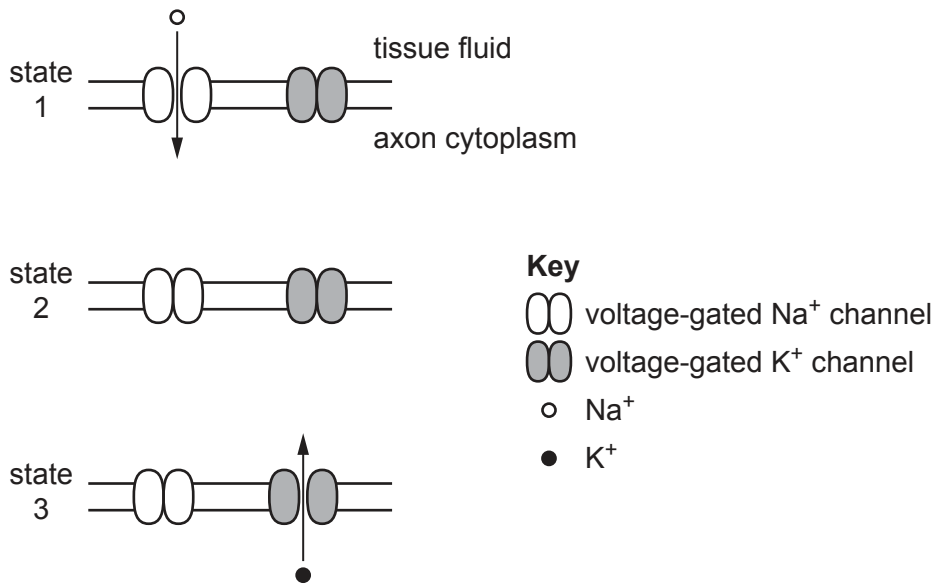

Fig. 9.1

Fig. 9.2 is a diagram of different phases of an action potential in an axon. The phases are labelled A, B, C, D, E, F and G.

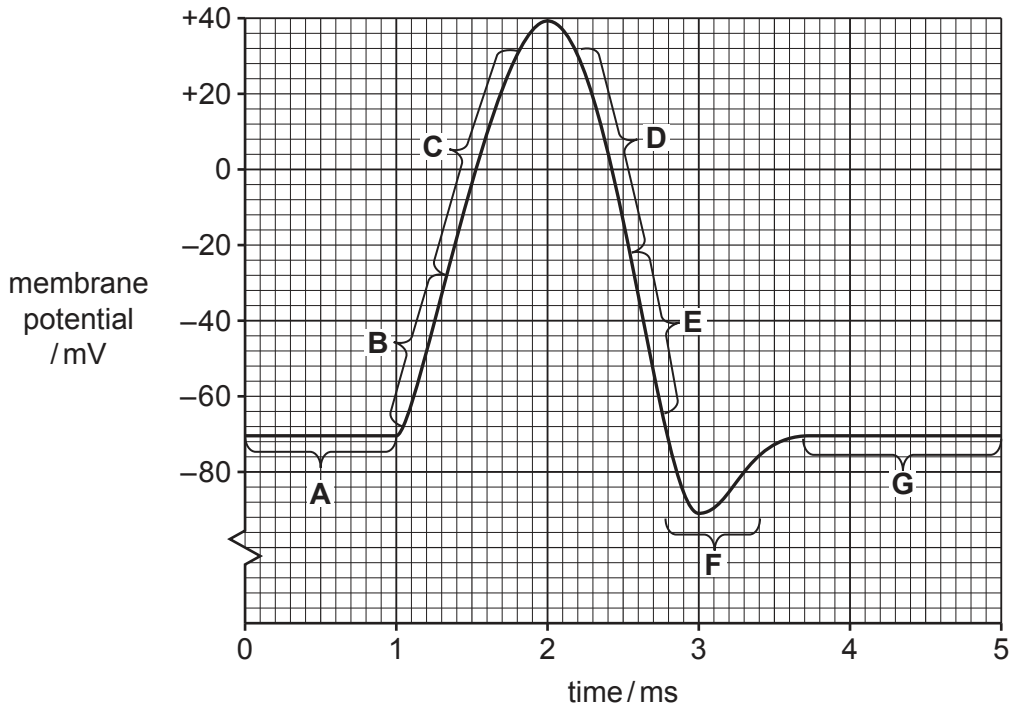

Fig. 9.2



Complete Table 9.1 to match each of the listed phases of the action potential with the appropriate state of the voltage-gated channels: **1, 2** or **3**.

Table 9.1

| phase of action potential | state of voltage-gated channels |
|---------------------------|---------------------------------|
| <b>A</b>                  | .....                           |
| <b>C</b>                  | .....                           |
| <b>E</b>                  | .....                           |
| <b>F</b>                  | .....                           |
| <b>G</b>                  | .....                           |

[3]

(b) Many neurones are surrounded by myelin sheaths.

Describe **and** explain the role of the myelin sheath in the transmission of an action potential.

.....

.....

.....

.....

.....

.....

.....

.....

.....

.....

..... [3]

[Total: 6]

10 (a) Glucagon has a role in the maintenance of blood glucose concentration.

Fig. 10.1 shows the relationship between blood glucose concentration and blood glucagon concentration, measured over 90 minutes in a healthy person. The person did not have any food in the three hours before the measurements were taken.

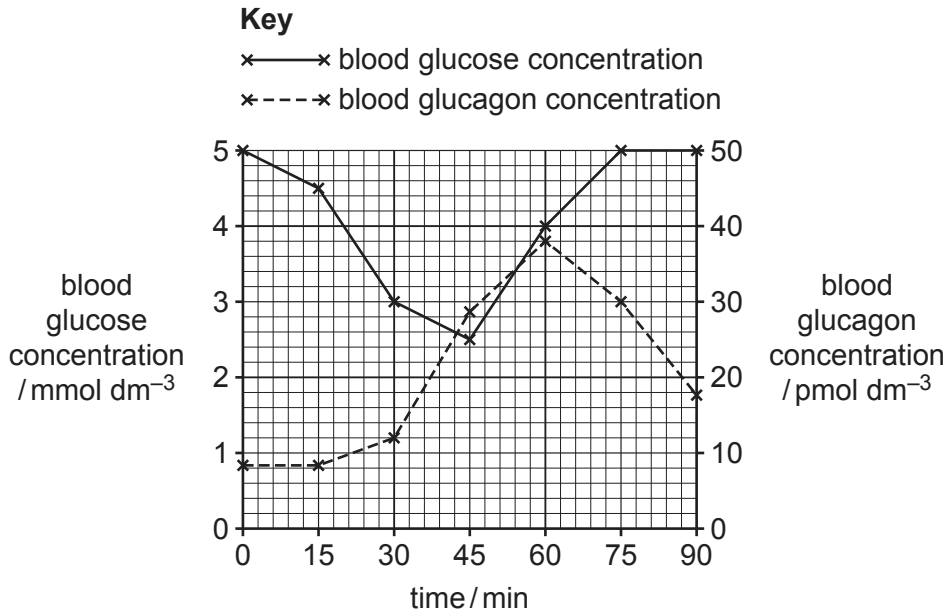

**Fig. 10.1**

Explain the relationship shown in Fig. 10.1.

.....

.....

.....

.....

.....

.....

.....

.....

.....

.....

.....

.....

.....

.....

.....

.....

.....

.....

.....

.....

.....

.....

.....

.....

[4]

- (b) The passage below outlines cell signalling.

Complete the passage by using the most appropriate scientific terms.

Cells need to interact with their environment and other cells around them. This is called cell signalling. Cells in mammals are involved in a complex system of communication with each other. For example, liver cells detect signals using receptors in their cell surface membranes. Glucagon binds to the receptors because its shape is .....

This binding activates a ....., leading to stimulation of the enzyme .....

[3]

[Total: 7]

**BLANK PAGE**

---

The boundaries and names shown, the designations used and the presentation of material on any maps contained in this question paper/insert do not imply official endorsement or acceptance by Cambridge Assessment International Education concerning the legal status of any country, territory, or area or any of its authorities, or of the delimitation of its frontiers or boundaries.

Permission to reproduce items where third-party owned material protected by copyright is included has been sought and cleared where possible. Every reasonable effort has been made by the publisher (UCLES) to trace copyright holders, but if any items requiring clearance have unwittingly been included, the publisher will be pleased to make amends at the earliest possible opportunity.

To avoid the issue of disclosure of answer-related information to candidates, all copyright acknowledgements are reproduced online in the Cambridge Assessment International Education Copyright Acknowledgements Booklet. This is produced for each series of examinations and is freely available to download at [www.cambridgeinternational.org](http://www.cambridgeinternational.org) after the live examination series.

Cambridge Assessment International Education is part of Cambridge Assessment. Cambridge Assessment is the brand name of the University of Cambridge Local Examinations Syndicate (UCLES), which is a department of the University of Cambridge.